

EEL 3302; ELECTRONICS I

CAD #3 — 10/22/07

Student _____
(Print Name Clearly)

INSTRUCTIONS

1. All CAD assignment write-ups must contain the following elements presented in order.
 - a) This page with name and signature affixed.
 - b) A summary page containing PSPICE results compared with formulae and calculator (“by hand”) results, together with an explanation of any differences. Summary is page 1.
 - c) A complete PSPICE circuit diagram (schematic) showing the bias voltages and currents, a complete listing of the PSPICE output file, and all graphs required by the assignment for each separate simulation. You may have to repeat this section several times depending on the assignment.
 - d) The “by hand” calculations and any associated required figures.
2. Use a comprehensive word processing application (such as WORD®) to assemble your report. All pages must have a printed header or footer (your choice) containing the CAD assignment number, student name, date and page number. All tables, schematics, graphs, and drawings must be captioned starting with Table 1, Figure 1, etc. Reference the page and figure caption for data presented on the summary page. Mark the location on any graph where data is taken for the summary page. Orient figures to give the largest possible presentation and do not place more than one figure on a page. Reverse the PSPICE graph background from black to white. The “by hand” calculations and figures may be handwritten but all other requirements must be satisfied. Use 8½” x 11” new unused printer paper for all PSPICE results and the “by hand” calculations and any associated required figures. Do not print or write on the back side of any page. “Portrait” pages must have the top aligned with the top of the stack. “Landscape” pages must have the top aligned with the left of the stack. Secure all pages with one staple in the far upper left corner of the stack. All material on each page should be visible. Work failing to conform to these specifications will not be accepted and a grade of “0” will be assigned. Late write-ups will not be accepted without good cause, e.g., documented medical problem, employer required travel.
3. Students are encouraged to collaborate in the initial effort where the emphasis is on understanding and determining a course of action. Students are prohibited from any collaboration, cooperation and conversation in the performance of the simulation, “by hand” analysis and write-up. Write-ups that are unacceptably similar will be challenged and may be considered as academic dishonesty.

This work is solely the product of my effort. I have neither given nor received assistance related to this assignment, and I have read, understood and complied with the requirements of this assignment to the best of my knowledge.

(signature)

EEL 3302; ELECTRONICS I

CAD #3 — 10/22/07

This CAD exercise demonstrates the operation of a single-stage common-source amplifier using the circuit shown in Figure 1. For this amplifier use the breakout library MbreakN MOSFET with $K_P = 0.001$, $V_{TO} = 1$, $W = 1E-6$, $L = 2E-7$, $CGSO = 5E-6$, $CGDO = 2E-6$, and $LAMBDA = 0.02$. In the circuit use $V_{DD} = 10$ volts, $CC_I = C_{C_O} = 1nF$, $R_{G1} = 4M\Omega$, $R_{G2} = 1M\Omega$, $R_D = 2k\Omega$, $R_L = 5k\Omega$ and $R_{sig} = 75\Omega$.

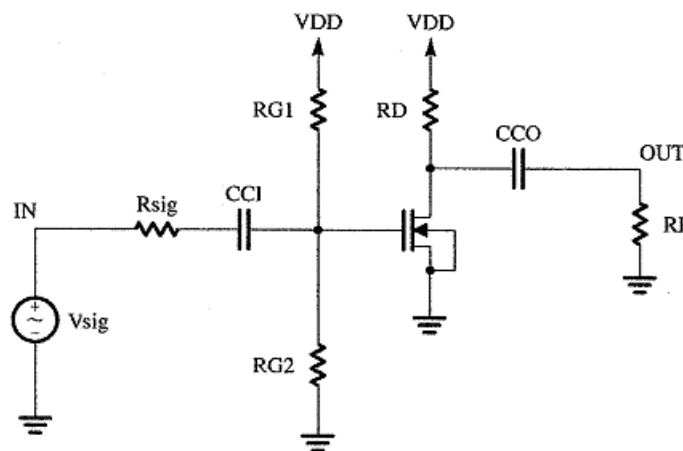

Figure 1 AC-Coupled Common-Source Amplifier

Construct a test setup for the circuit shown in Figure 1.

Perform a PSPICE dc analysis to verify that the amplifier will function.

Perform a PSPICE ac analysis to determine the overall voltage gain frequency response. Identify and mark the mid-band gain at a nominal mid-band frequency. Identify and mark the lower and upper 3-dB frequencies. Perform a PSPICE ac analysis to determine the output resistance frequency response. Identify and mark the mid-band output resistance at the same frequency as the mid-band gain. Plot the gain frequency response and output resistance frequency response on the same graph. A single schematic diagram and output file listing can be used for both simulations in your report.

Perform a PSPICE transient analysis at the mid-band frequency to determine maximum drain voltage and minimum drain voltage for 10% total harmonic distortion. Enable output file Fourier analysis for 10 harmonics. Plot the drain voltage and mark the maximum and minimum values.

EEL 3302; ELECTRONICS I

CAD #3 — 10/22/07

Calculate the bias voltages and currents, the maximum drain voltage and minimum drain voltage, the mid-band output resistance, the mid-band voltage gain, and the 3-dB frequencies by hand. Use the device parameter values from the PSPICE output file for your calculations. Compare the calculated values with the values from the simulation. Compare the drain bias voltage from the simulation with the dc value in the Fourier analysis from the simulation.

This assignment is due at the beginning of class on Wednesday, October 31, 2007.