

**ANSWERS TO SELECTED PROBLEMS**  
**APPLIED ELASTICITY**  
**ADVANCED STRENGTH OF MATERIALS**  
**FOURTH EDITION (THIRD EDITION PROBLEM#s IN BRACKETS)**

**Chapter 1**

1.1 (1.1)  $P_{all} = 4.27 \text{ kN}$

1.2 (1.2) a)  $\tau_{x'y'} = -16.08 \text{ MPa}$ , b)  $\tau_{x'y'} = -25 \text{ MPa}$ .

1.6 (1.5)  $F = 67.32 \text{ kN/m}^3$

??? (1.9) a)  $\sigma_1 = 121 \text{ MPa}$ ,  $\sigma_2 = -71 \text{ MPa}$ ,  $\tau_{max} = 96 \text{ MPa}$

$\phi_p = -19.3^\circ$ ,  $\phi_s = 25.7^\circ$

b)  $\sigma_1 = 200 \text{ MPa}$ ,  $\tau_2 = -50 \text{ MPa}$ ,  $\tau_{max} = 125 \text{ MPa}$

$\phi_p = 26.58^\circ$ ,  $\phi_s = 71.55^\circ$

1.18 (1.14)  $P = 3 \pi pr^2$

1.23 (1.16)  $\sigma_1 = 37.84 \text{ MPa}$ ,  $\sigma_2 = -4.18 \text{ MPa}$ ,

1.29 (1.22)  $\sigma_x = -40 \text{ MPa}$ ,  $\sigma_y = 20 \text{ MPa}$ ;

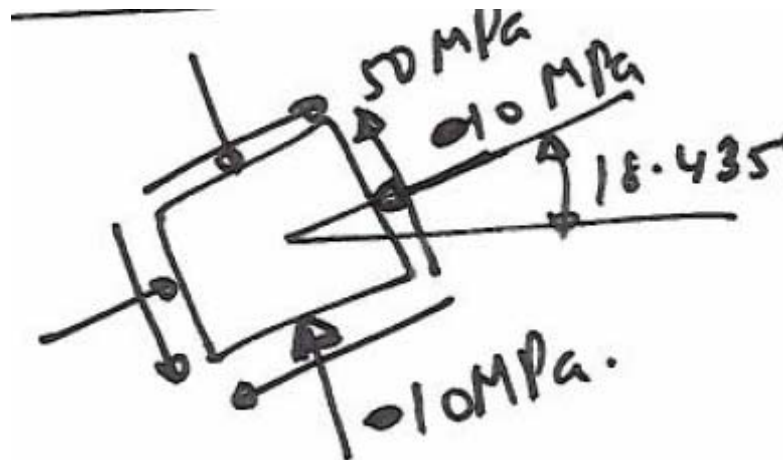
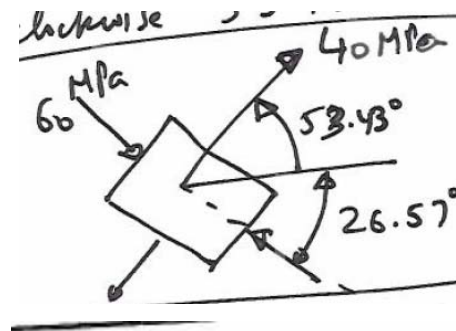

1.39 (1.29)  $p_{\text{all}} = 493 \text{ kPa}$ .

1.40 (1.30) 
$$\begin{bmatrix} 25.342 & -2.66 & -7.99 \\ -2.66 & -5.392 & 16.16 \\ -7.99 & 16.16 & 6 \end{bmatrix} \text{MPa}, I_1=26 \text{ MPa}, I_2=-349 \text{ MPa}^2, I_3=-6464 \text{ MPa}^3$$

1.43 (1.33) 
$$\sigma_1 = 66.016 \text{ MPa}, \sigma_2 = 28.418 \text{ MPa}, \sigma_3 = -44.479 \text{ MPa}$$
  

$$l_1 = 0.9556, m_1 = 0.1688, n_1 = 0.2416$$

1.49 (1.38) 
$$\sigma_{1,2} = \frac{\sigma_x + \sigma_y}{2} \pm \sqrt{\left(\frac{\sigma_x - \sigma_y}{2}\right)^2 + \tau_{xy}^2}$$

1.53 (1.42) 
$$\sigma = 51.42 \text{ MPa}, \tau = 7.413 \text{ MPa}$$

## Chapter 2

2.2 (2.2)  $L_{A'B'} = 2000.4 \text{ mm}; L_{A'D'} = 1498.9 \text{ mm}; \gamma_{xy} = 300 \mu$

$X'_A = 1000.225 \text{ mm}; Y'_A = 500.025 \text{ mm}$

2.3 (2.3) 
$$\begin{bmatrix} 0 & 0 & -100 \\ 0 & 200 & 200 \\ -100 & 200 & 200 \end{bmatrix} \mu$$

2.8 (2.8)  $-808 \mu; 36.65^0$

2.9 (2.9)  $A_{QB} = 0.01 \text{ mm}, A_{AC} = 0.00617 \text{ mm}$

2.25 (2.23)  $\epsilon_1 = 112 \mu, \epsilon_2 = -112 \mu; \sigma_1 = 17.2 \text{ MPa}, \sigma_2 = -17.2 \text{ MPa};$

2.26 (2.28)  $\epsilon_x = 522 \mu, \epsilon_y = 678 \mu; \gamma_{xy} = -1873 \mu$

2.35 (2.32).  $\sigma_1 = 139.947 \text{ MPa}; \sigma_2 = 129.757 \text{ MPa}; \sigma_3 = 119.513 \text{ MPa}$

2.43 (2.39) a)  $p = 550 \text{ MPa}$  b)  $U = 19.439 \text{ kN-m}$

2.48 (2.43) a)  $U = 60.981 \frac{T^2 a}{\pi d^4 G}$  b)  $U = 2.831 \text{ kN-m}$

2.49 (2.44). Answer already given

2.52 (2.45). 12.96

## Chapter 3

3.5 (3.3)  $\sigma_x = 2c, \sigma_y = 2a, \tau_{xy} = b$

$\sigma_x = 2cx + 6dy, \sigma_y = 6ax + 2by, \tau_{xy} = -2bx - 2cy$

3.10 (3.5) a)  $\sigma_x = 0, \quad \sigma_y = 6pxy, \quad \tau_{xy} = -3px^2$

c)  $x = 0: V_y = P_x = 0$

$x = a: P_x = 0; V_y = 3pa^2bt$

$Y = 0: P_y = 0; V_x = pa^3t$

$y = b: V_x = pa^3t; P_y = 3pa^2bt$

3.13 (3.7)  $\sigma_x = \frac{2Px^3}{\pi(x^2 + y^2)^2} \quad \sigma_y = \frac{2Pxy^2}{\pi(x^2 + y^2)^2} \quad \tau_{xy} = \frac{2Px^2y}{\pi(x^2 + y^2)^2}$

3.18 (3.11) Already given in problem

3.19 (3.12) Only equilibrium eqns are satisfied, not compatabality.

$\epsilon_1 = 32.8\mu; \quad \epsilon_2 = -106 \mu; \quad \theta_p = 5.65^\circ$

3.40 (3.32)  $\frac{5pd}{4t}; \quad \frac{25pd}{64t}$

#### Chapter 4

4.3 (4.2) a)  $\tau_{yp} \cong -152.6MPa$  b)  $\tau_{yp} \cong 134.9MPa$

4.5 (4.4)  $t_{all} = 8.45 \text{ mm}$

4.6 (4.5) a)  $d = 27.95 \text{ mm}$  b)  $d = 36.8 \text{ mm.}$

4.7 (4.6) a) Allowable stress 75.6 MPa - Failure occurs

b) Allowable stress 70 MPa - No Failure

4.9 (4.8) a)  $f_s = 17.3$  b)  $f_s = 17.3$

4.11 (4.10) a)  $R = 932 \text{ N}$  b)  $R = 959 \text{ N}$

4.13 (4.12) a)  $p = 6.466 \text{ MPa}$  b)  $p = 5.6 \text{ MPa}$

4.18 (4.17) a) failure occurs b) no fracture

#### Chapter 8

8.2 (8.2)  $P_{all} = 51.2 \text{ MPa}$

8.3 (8.3) b)  $27.12 \text{ mm}$

8.10 (8.10)  $p_o = 111.11 \text{ MPa}$

8.16 (8.16)  $T = 5.073 \text{ kN-m}$

8.25 (8.24)  $r = \sqrt{ab}, \quad \sigma_{r,max} = p\omega^2(b-a)^2 \quad \sigma_{\theta,max} = \frac{3+\nu}{4}p\omega^2(b-a)^2$

8.29 (8.27)  $t_r = 238.1 \text{ mm}; \quad \sigma_{\theta,max} = 180.1 \text{ MPa}$

8.33 (8.30)

Force = 2344 kN/m

**Chapter 10**

10.30 (10.23)  $v_A = \frac{PL^3}{3EI}$

10.32 (10.24)  $v = \frac{Px^2(3L-x)}{6EI}$

10.33 (10.25)  $v_B = \frac{Pc^2(L-c)^2}{4EIL}$

10.34 (10.26)  $v_{\max} = \frac{PL^3}{144EI}$