

EML 4230 Introduction to Composite Materials

Chapter 2 Macromechanical Analysis of a Lamina **Deformations of a Unidirectional Lamina Under Applied Loads**

Dr. Autar Kaw

Department of Mechanical Engineering
University of South Florida, Tampa, FL 33620

Courtesy of the Textbook

[Mechanics of Composite Materials by Kaw](#)



Typical Laminate

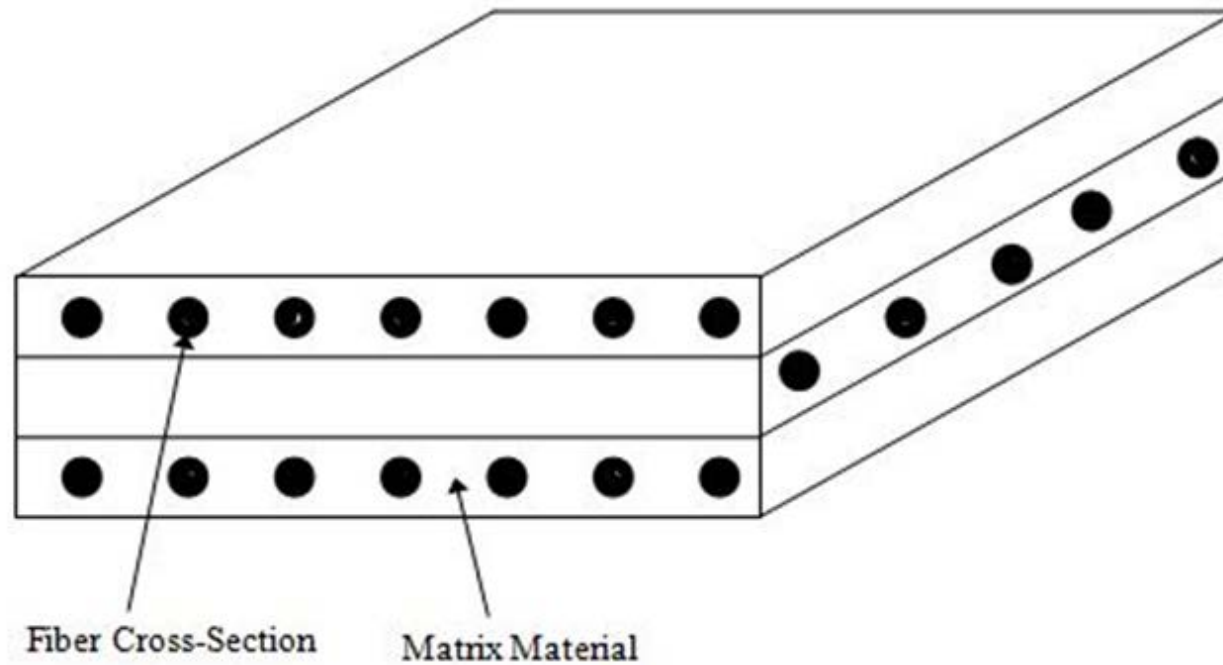

FIGURE 2.1
Typical laminate made of three laminas

Deformation of Unidirectional Lamina

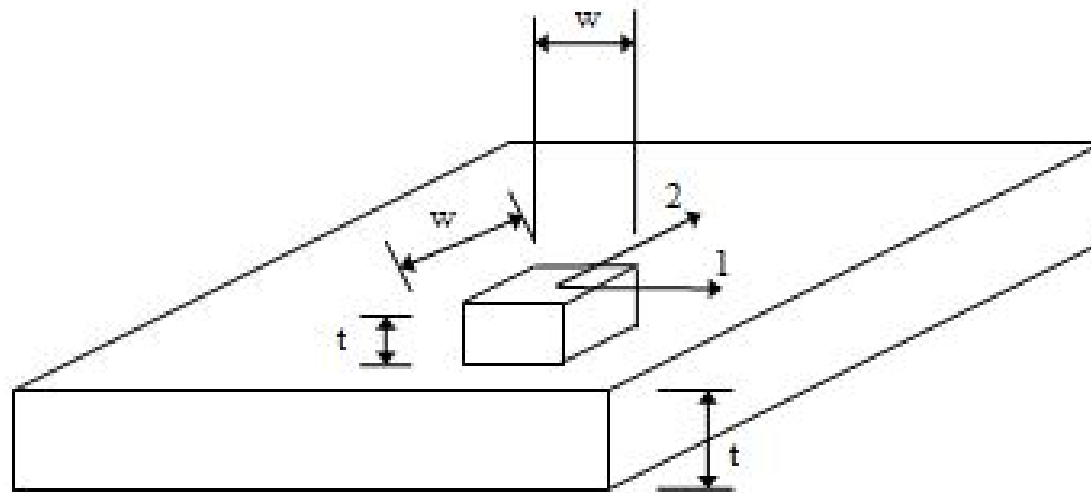

FIGURE 2.2
Deformation of square, isotropic plate
under normal loads

Deformation of Unidirectional Lamina

$$\delta_{1A} = \delta_{2B},$$

$$\delta_{2A} = \delta_{1B}$$

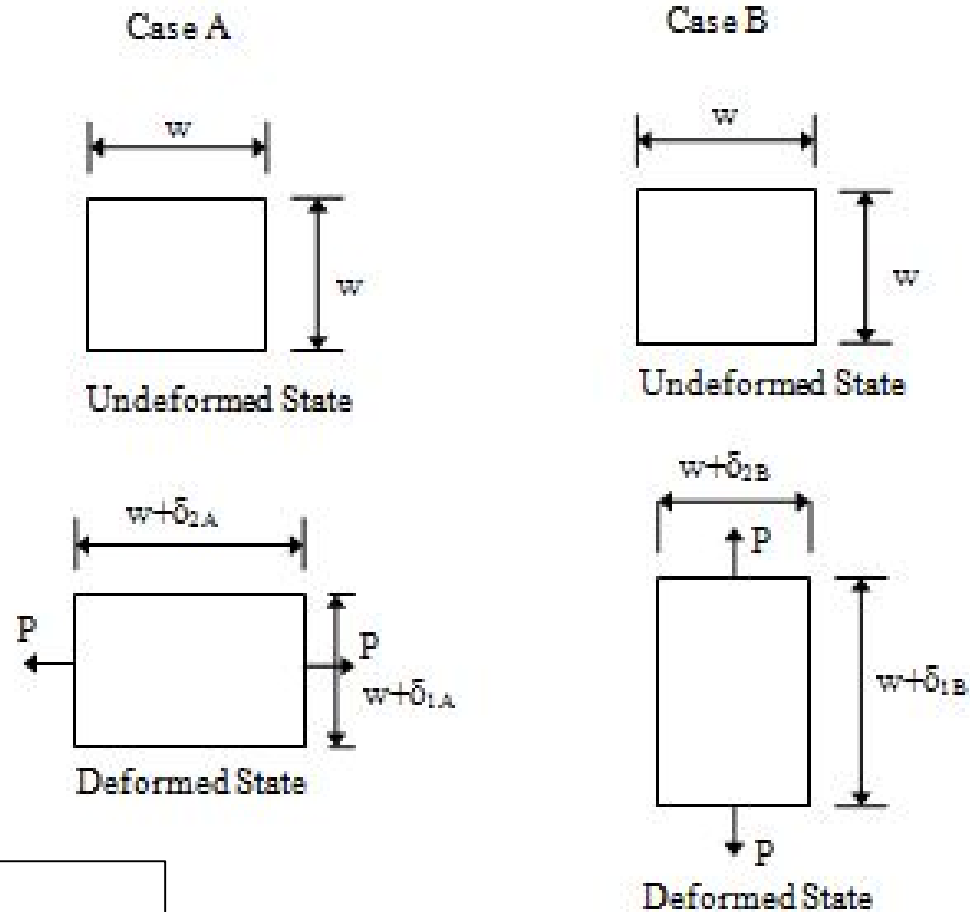

FIGURE 2.2
Deformation of square, isotropic plate
under normal loads

Deformation of Unidirectional Lamina

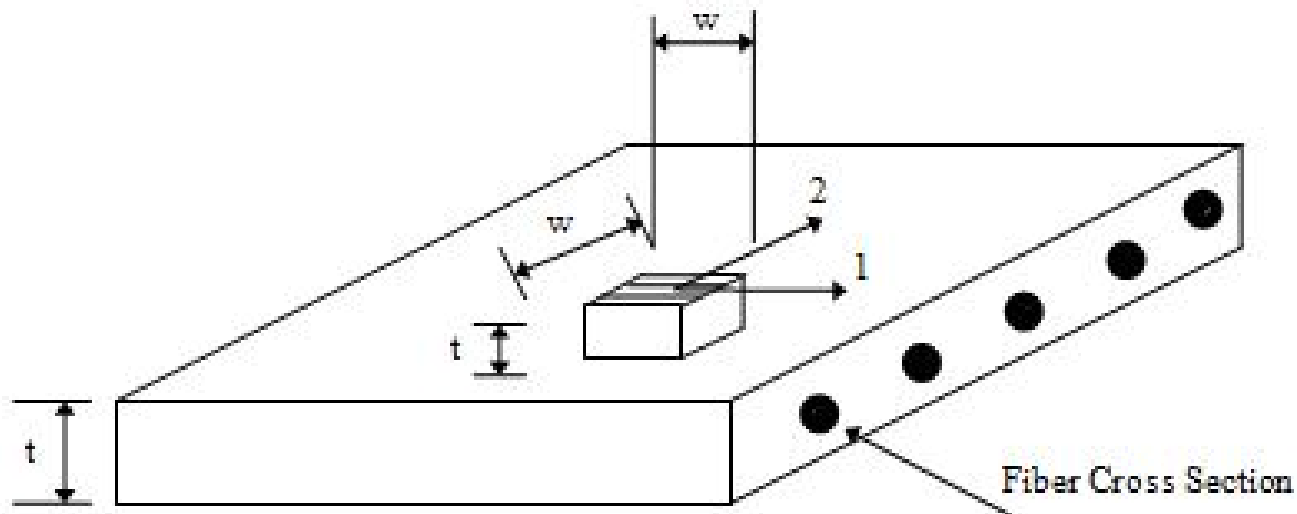

FIGURE 2.3

Deformation of square, unidirectional lamina with fibers at zero angle under normal loads

Deformation of Unidirectional Lamina

$$\delta_{1A} \neq \delta_{2B},$$

$$\delta_{2A} \neq \delta_{1B}$$

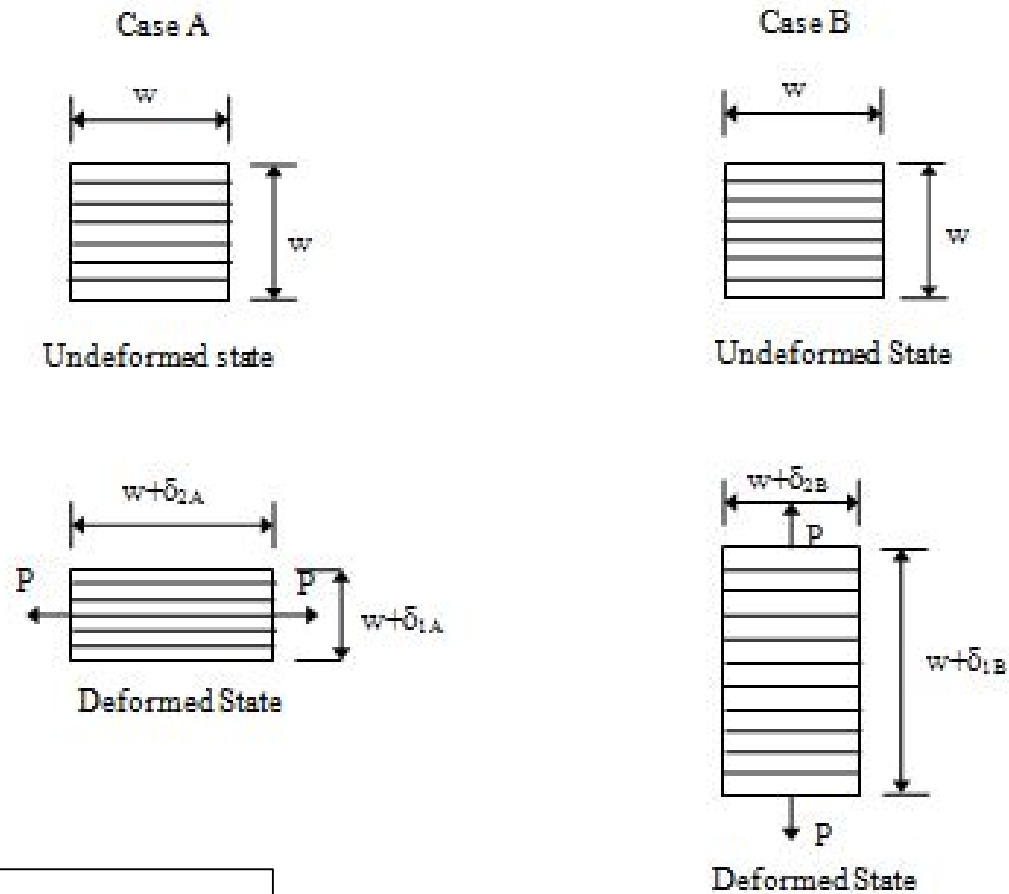

FIGURE 2.2
Deformation of square, unidirectional lamina with fibers at zero angle under normal loads

Deformation of Unidirectional Lamina

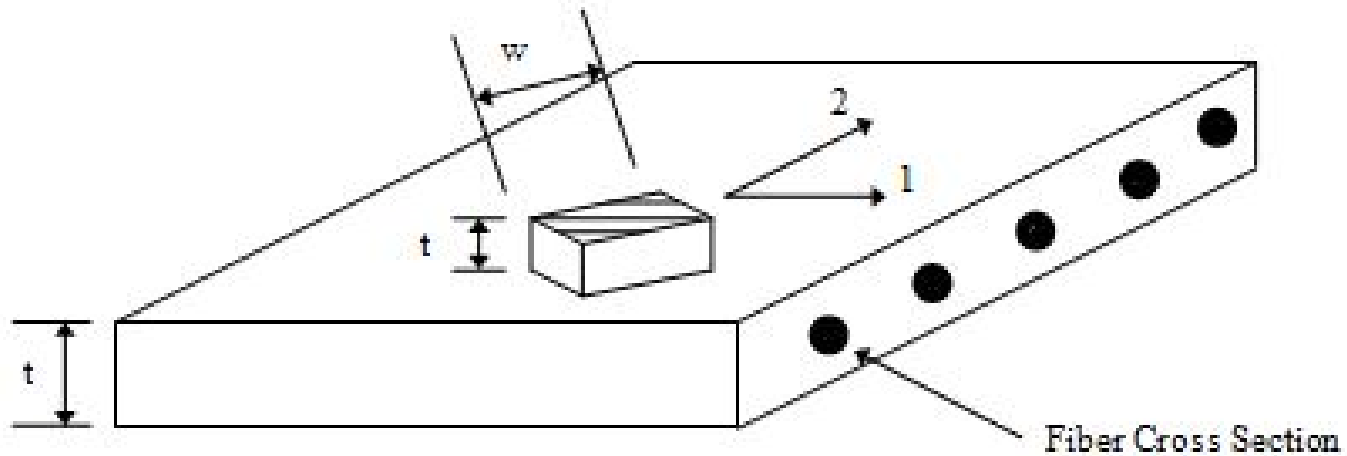

FIGURE 2.4

Deformation of square, unidirectional lamina with fibers at an angle to normal loads

Deformation of Unidirectional Lamina

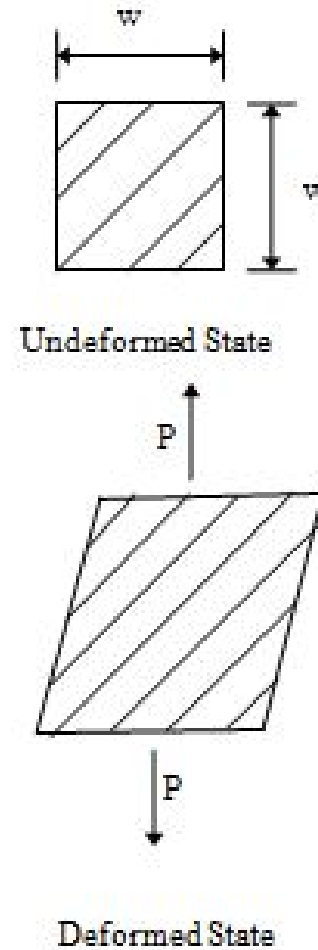

FIGURE 2.4
Deformation of square, unidirectional lamina
with fibers at an angle to normal loads

END